

## Application of Leaded Resistors in Energy Meters

An electric meter or energy meter is a device that measures the amount of electrical energy supplied to a residence or business. It is also known as (k)Wh meter.

The main unit of measurement in the electricity meter is the kilowatt-hour which is equal to the amount of energy used by a load of one kW over a period of one hour.



### TYPES OF METERS

Modern electricity meters operate by continuously measuring the instantaneous voltage (V) and current (A) and finding the product of these to give instantaneous electrical power (W) which is then integrated against time to give energy used (J, kWh etc). The meters fall into two basic categories, electromechanical and electronic (solid state).

Meters are available in single phase and three phase (also called trivector) meter.

A single phase meter generally finds applications in all residential complexes, while three phase meter is widely used for commercial and industrial purpose.

Choosing between either depends on the total load and types of loads that need to be served.

### ELECTROMECHANICAL METER

The most common type of electricity meter is the electromechanical induction meter.

The electromechanical induction meter operates by counting the revolutions of an aluminum disc which is made to rotate at a speed proportional to the power. The number of revolutions is thus proportional to the energy usage.

### ELECTRONIC METER (SOLID STATE METER)

The figure shows typical block diagram of a solid-state electronic meter. The power used is displayed on an LCD, while advanced electronic meters can be read automatically using communication ports like optical port, RS232 or RF modules.

Most solid-state meters use a current transformer or shunt, energy metering IC and LCD display. The IC measures voltage and current, and generates a pulse output proportional to power.

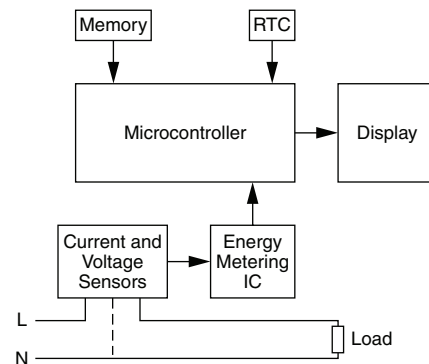

Basic Blocks of Electronic Energy Meter

An electronic meter provides an order of substantial improvement in measurement accuracy over that of a mechanical meter, while lowering the meter's power consumption. Another plus is the electronic energy meter's ability to detect and guard against meter tampering.

## Application of Leaded Resistors in Energy Meters

### TYPICAL USAGE OF LEADED RESISTORS IN ENERGY METER

#### CAPACITIVE DROP POWER SUPPLY

##### • Power Supply Section in Energy Meter

The power supply in electronic meter is generally a capacitive drop power supply where voltage at the load remains constant as long as current out ( $I_{out}$ ) is less than in current ( $I_{in}$ ). The main advantages of using capacitive drop power supply is that it is significantly smaller than the transformer based one, more cost effective than transformer based or switch mode based and immune to magnetic effects.

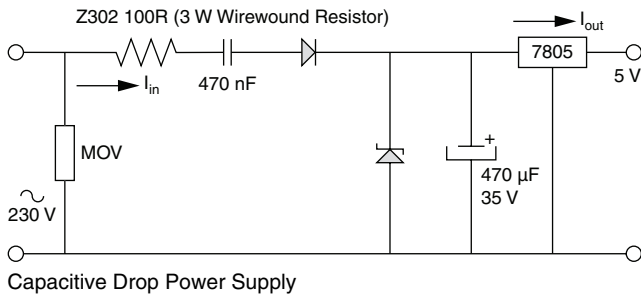

##### • Function of Wirewound Resistor in Power Supply

The resistor limits inrush current. The value is so chosen that it does not dissipate too much power yet is large enough to limit inrush current. The current through the resistor is full wave current equivalent to line voltage divided by impedance of line capacitor.

VR68 performs dual role of a surge resistor and a voltage sense resistor.

#### TAMPER DETECTION CIRCUIT

Connecting only phase wire to the meter and neutral directly to load can tamper meters bypassing the metering circuit. To prevent this additional CT is used to monitor tampering. Circuit can be powered with current present in single wire i.e without connecting neutral. Under small load condition the CT creates enough voltage, which is used to power ON the metering circuit. The resistor used in circuit is to restrict flow of current so that stable output is obtained.

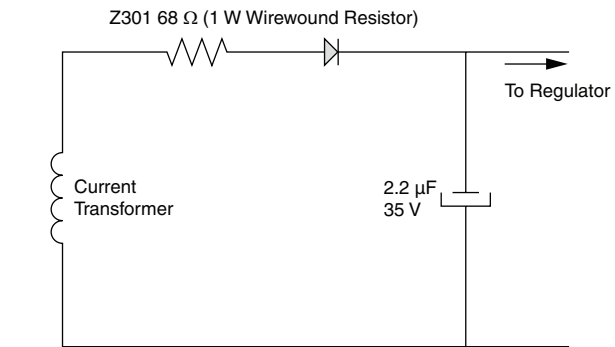

Tamper Detection Circuit

#### METERING CIRCUIT

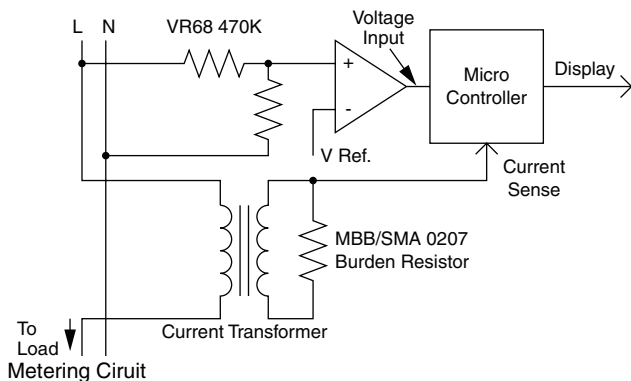

The key feature of an electronic meter is its measurement accuracy. In order to satisfy this condition it is required that the sensing circuitry should be precise and accurate.

The voltage sensing circuit consists of a resistor divider network consisting of a high voltage VR68 resistor and a current sensing consisting of a precision resistor MBB/SMA 0207.

## Application of Leaded Resistors in Energy Meters

### FEATURES/BENEFITS OF VISHAY LEADED RESISTORS

#### Z300 Wirewound Resistors

[www.vishay.com/doc?21007](http://www.vishay.com/doc?21007)



#### FEATURES

- All welded construction
- Non flammable cement coating
- Ceramic core
- Various kinds of lead forming available
- High pulse loading capability
- Available in 1 W to 10 W with wide ohmic range and tolerance

#### VR68 High Ohmic/High Voltage Resistors

[www.vishay.com/doc?28734](http://www.vishay.com/doc?28734)

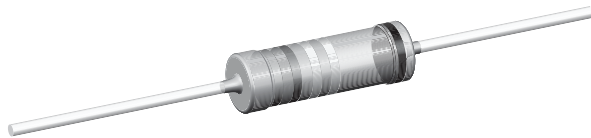

#### FEATURES

- High pulse loading capability (10 kV)
- Small size (0718)
- Meet the safety requirements of:  
"UL1676" (510 k $\Omega$  to 11 M $\Omega$ ); file no: E171160  
"IEC 60065" "EN60065"  
"VDE 0860" (Germany)  
"CQC" (China)

#### MBB/SMA 0207 Precision Metal Film Resistors

[www.vishay.com/doc?28767](http://www.vishay.com/doc?28767)

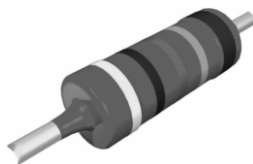

#### FEATURES

- Advanced thin film technology
- Low TCR/tolerance (15 ppm, 0.1 %)
- Superior class 0.05 stability
- Wide precision range: 10R to 1M5
- CECC certified